

RUNNER
R 150 FD 85





RUNNER
R 150 FD 100

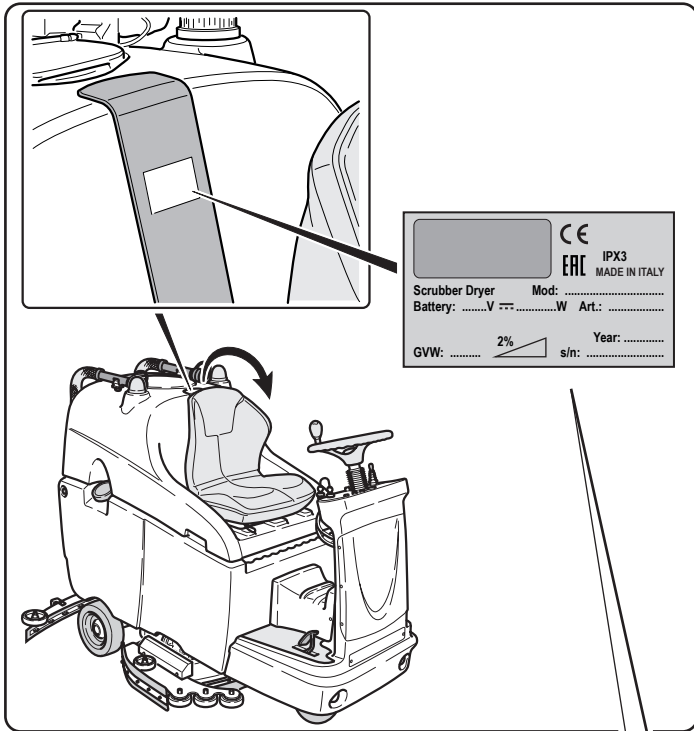

EN Use and Maintenance

CE

49.0295.00
ed. 01/2023

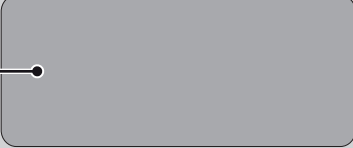

CE
EAC IPX3
 MADE IN ITALY
 Scrubber Dryer Mod:
 Battery:VW Art:
 GVW:  Year:
 s/n:

CE
EAC IPX3
 MADE IN ITALY
 Scrubber Dryer Mod:
 Battery:VW Art:
 GVW:  Year:
 s/n:

1 ———●
 2 ———●
 3 ———●
 4 ———●
 5 ———●
 6 ———●
 7 ———●
 8 ———●

	1	2	3	4
IT	Produttore	Caratteristiche elettriche	N° Matricola	Grado di protezione
EN	Manufacturer	Electrical characteristics	Serial N°	Degree of protection
FR	Producteur	Caractéristiques électriques	N° Matricule	Degré de protection
DE	Hersteller	Elektrische Eigenschaften	Serien-Nr.	Schutzgrad
ES	Fabricante	Características eléctricas	N° Matricola	Grado de protección
PT	Produtor	Características eléctricas	Número de série	Grau de protecção
NL	Producent	Elektrische eigenschappen	Serienummer	Beschermingsgraad
CS	Výrobce	Elektrické údaje	Výrobní č.	Úroveň ochrany
RU	Изготовитель	Электрические характеристики	Заводской №	Βαθμός προστασίας
PL	Producent	Specyfikacja elektryczna	Numer seryjny	Stopień zabezpieczenia
AR	الصانع	المواصفات الكهربائية	الرقم التسلسلي	درجة الحماية

	5	6	7	8
IT	Peso in ordine di marcia	Anno di costruzione	Codice articolo	Modello
EN	Weight in running order	Year of manufacture	Item code	Model
FR	Poids en ordre de marche	Année de construction	Référence de l'article	Modèle
DE	Gewicht bei Betrieb	Baujahr	Artikelnummer	Modell
ES	Peso en orden de marcha	Año de fabricación	Código del artículo	Modelo
PT	Peso em ordem de marcha	Ano de construção	Código do artigo	Modelo
NL	Gewicht in rijklare toestand	Bouwjaar	Artikelcode	Model
CS	Hmotnost v provozním stavu	Rok výroby	Kód položky	Model
RU	Βάρος στην λειτουργία	Έτος κατασκευής	Κод изделия	Μodelή
PL	Ciężar podczas eksploatacji	Rok produkcji	Kod artykułu	Model
AR	الوزن في وضعية التشغيل	سنة الصنع	رمز المنتج	الطراز



English EN - 1
(Translation of original instructions)

*Dear Customer,
Thank you for choosing one of our cleaning products.*

The floor scrubber dryer that you have purchased has been designed to satisfy the user in terms of ease of use and reliability over time.

We are aware that in order for a good product to stay that way, over time, it requires continuous updates aimed at meeting the expectations of those who use it on a daily basis. For this reason, we hope that you will not only be a satisfied customer but also a partner who does not hesitate to give us your opinions and ideas originating from your personal day-to-day experience.

Index

Technical data	EN-3
1.1 Introduction	EN-5
1.1.a - Operator position	EN-5
1.1.b - General warnings while using the machine	EN-5
1.1.c - General warnings during maintenance.....	EN-5
1.2 Non-intended machine use	EN-5
1.3 Demolishing the machine	EN-5
2.1 Getting to know the machine	EN-5
3.1 Unpacking	EN-5
3.1.a - Battery installation	EN-6
3.1.b - Unloading the machine from the wooden pallet	EN-6
3.1.c - Standard machine equipment.....	EN-6
4.1 Assembly components	EN-6
4.1.a - Squeegee installation	EN-6
5.1 Charging th battery	EN-6
5.1.a - Charging the battery with an external battery charger.....	EN-7
6.1 Machine controls	EN-7
6.1.a - Control panel.....	EN-7
6.1.b - Accelerator pedal.....	EN-9
7.1 Display	EN-9
8.1 Parameter setting	EN-10
8.1.a - Language setting.....	EN-11
8.1.b - Battery type setting.....	EN-11
8.1.c - Brightness and contrast setting	EN-12
8.2 Emergency	EN-12
8.3 Safety devices	EN-12
8.4 Alarms during the functioning	EN-13
9.1 Filling the tank	EN-15
9.2 Detergent / chemical tank	EN-15
10.1 Operation	EN-15
10.1.a - Checks before use.....	EN-15
10.1.b - Preparing the machine and choosing the cycle	EN-15
10.1.c - Using the machine.....	EN-16
10.1.d - End of use and shutdown	EN-16
11.1 Draining the recovery water	EN-17
12.1 Maintenance and cleaning	EN-17
12.1.a - Emptying and cleaning the clean water tank	EN-17
12.1.b - Cleaning the recovery water tank	EN-17
12.1.c - Cleaning the wiper	EN-18
12.1.d - Cleaning the side skirts	EN-18
12.1.e - Check the wear status of the steering chain.....	EN-18
12.1.f - Replacing the brushes.....	EN-18
12.1.g - Cleaning the clean water filter	EN-19
12.1.h - Replacing the squeegee rubber blades.....	EN-19
12.1.i - Replacing the side skirt rubbers	EN-19
12.1.j - Adjusting the pressure of the squeegee	EN-19
12.1.k - Checking the wear status of the three wheels.....	EN-20
12.1.l - Replacing the fuses.....	EN-20
12.1.m - Battery charger configuration	EN-20
Troubleshooting	EN-21
Wiring diagram	EN-23

Technical data

	R150 FD85	R150 FD100
Type of use	Operator on board	
Characteristics		
Operation	Batteries	
Type of batteries	N° 6 - 6V - 240Ah - (C5)	
Power supply	Battery 36V	
Installed load	2650 W	2650 W
Forward movement	Forward / reverse movement	
Washing width	850 mm	1000 mm
Drying width	1100 mm	1300 mm
Theoretical hourly working capacity	5000 m ² /h	6000 m ² /h
Hand-arm system vibration	2.03 m/s ²	
Full body vibration	0.63 m/s ²	
Sound pressure	67 db(A) Norm. / 59 db(A) Low Noise	
Uncertainty KpA	0.75 dB (A)	
Brushes		
Diameter / pad / number	440 mm / 17" x 2	508 mm / 20" x 2
Motor power / number	500 W x 2	500 W x 2
Motor speed	135 rpm	135 rpm
Specific pressure	23 / 29 / 39 gr / cm ²	24 / 29 / 37 gr / cm ²
Traction		
Maximum cleaning gradeability	2 %	
Maximum slope vacuum surmountable	16 % (Maximum ramp length: 4.5 m)	
Motor power	900 W	
Maximum forward speed while in function	6 km/h	

	R150 FD85	R150 FD100
Aspiration		
Motor power	600 W	
Negative pressure (water column)	165 / 1700 mbar / mmH ₂ O	
Air flow rate	32 l / sec	
Tank		
Type	Dual tank	
Recirculation	No	
Solution capacity	150 l	
Recovery capacity	160 l	
Dimensions	1850 x 1020 x 1380 mm	1850 x 1100 x 1380 mm
Battery compartment size (length x width x height)	2 compartments - 540 x 295 x 380 mm	
Weight		
Empty weight	290 Kg	302 Kg
Weight with batteries	578 Kg	590 Kg
Vehicle curb weight	808 Kg	820 Kg

1.1 INTRODUCTION



DANGER:

Before using the machine carefully read the “**SAFETY WARNINGS FOR FLOORS WASHER-DRYER**” manual annexed to this one and the additions indicated below.

1.1.a - Operator position

The operator, during the machine use is sitting on the seat with his hands on the steering wheel.

1.1.b - General warnings while using the machine

- DO NOT leave the machine unattended on inclined surfaces.
- It is absolutely forbidden to turn while on ramps; danger of tipping/overturning.
- Avoid using the machine in environments where there is a risk of falling objects.

1.1.c - General warnings during maintenance

- Do not use aggressive detergents, acid, lye etc. during cleaning and washing and take particular care with electrical parts.
- Do not wash the machine with direct or pressurised jets of water.

1.2 - NON-INTENDED MACHINE USE

- Do not operate the machine with the recovery tank open;
- Hands and feet must be kept on board while the machine is in motion;
- Do not make sudden turns, especially during downhill movements.



WARNING:

Only **ONE PERSON** at a time is to be permitted on board the machine.

1.3 - DEMOLISHING THE MACHINE



DANGER:

The machine's batteries are to be considered as special waste and must therefore be disposed of at appropriate collection facilities, as prescribed by the current regulations in the country of use.

2.1 - GETTING TO KNOW THE MACHINE (Fig. 1)

- 1) Steering-wheel.
- 2) Dashboard.
- 3) Seat.
- 4) Adjusting seat lever.
- 5) Battery socket/plug.
- 6) Foot rest.
- 7) Accelerator pedal.
- 8) Rear wheels.
- 9) Operating lights.
- 10) Flashing lights.
- 11) Recovery water tank.
- 12) Recovery water tank cover.
- 13) Clean water tank.
- 14) Clean water filling opening.
- 15) Recovery water drain hose.
- 16) Squeegee water aspiration hose.
- 17) Clean water drain hose.
- 18) Gas spring.
- 19) Brushes unit.
- 20) Squeegee.
- 21) Side skirts.
- 22) Water filter.
- 23) Traction directional wheel.

3.1 - UNPACKING (Fig. 2)

Once the packaging has been removed as shown in the instructions on the packaging itself, check that the machine and all the components supplied are intact.

If any evident damage is found, contact the area agent and the carrier within 3 days of receipt.

- Remove the pack (24) containing the accessories supplied.

3.1.a - Battery installation (Fig. 3)

- Lift the recovery water tank (11) using the appropriate handles (25).
The tank will be kept open by the gas spring (18).
- Place the batteries as shown in the picture, connecting them as indicated in the scheme, using the supplied cables and plugs.
- Connect the plug for the batteries (26) to the socket (5).
- Lower the recovery water tank (11) assisting the downward movement.

**NOTE:**

The batteries must be installed and connected by qualified personnel.

3.1.b - Unloading the machine from the wooden pallet (Fig. 4 - 5)

- Position a ramp (27) and fasten it to the wooden pallet.
- Remove the wooden blocks (28) from the three wheels.
- Sit on the seat in driving position.
- Turn the key (29) on "ON".
- Turn the potentiometer (30) to about half its stroke.
- Shift the movement direction selector (31) to "▲" (forward) or "▼" (reverse), then press the accelerator pedal (7) and drive down the pallet using the ramp.

3.1.c - Standard machine equipment (Fig. 6)

The accessories supplied are as follows:

- 32) Machine use and maintenance manual.
- 33) Battery charger instruction manual (if present).
- 34) 2 brushes (machine mounted).

4.1 - ASSEMBLY COMPONENTS

4.1.a - Squeegee installation (Fig. 7)

- Insert the squeegee (20) into its support plate (35) and fasten it by tightening the two knobs (36).
- Connect the suction tube (16) to the squeegee's intake opening.

5.1 CHARGING THE BATTERY

**DANGER:**

Charge the batteries in rooms which are well-ventilated and comply with applicable regulations in the country of use. For safety-related information, follow what is described in chapter 1 of this manual.

**WARNING:**

For information and warnings about the battery and on board battery charger (if present) follow what is described in the battery charger manual enclosed with this document.

**WARNING:**

When the machine leaves the factory, it is calibrated to operate with gel batteries. If other types of batteries are installed, see the paragraph "Parameter setting". The use of gel batteries with calibration for acid or other batteries is prohibited.

**NOTE:**

10 hours are needed for complete battery charging. Avoid partial recharges.

5.1.a - Charging the battery with an external battery charger (Fig. 8)

- Move the machine near the battery charging station.
- Remove the battery plug (26) from the socket (5) of the machine's electrical system.
- Connect the battery plug (26) to the external battery charger's outlet (37).
- Once the batteries have been charged, reconnect the battery plug (26) to the socket (5) of the machine's electrical system.

6.1 - MACHINE CONTROLS

6.1.a - Control panel (Fig. 9)

29) Ignition key

- Turned in a clockwise direction to "ON" it powers the circuits, enabling machine operation.
- Turned in an anti-clockwise direction to "OFF" it disconnects power to the circuits and can be removed.

30) Maximum speed adjustment potentiometer

It is possible to adjust the maximum speed from "0" to "6" km/h with the potentiometer (30).

- Turn the potentiometer (30) clockwise to increase the speed, turn it anticlockwise to decrease the speed.
- When the accelerator pedal is pressed the speed will be proportionate to the set maximum speed.

31) Movement direction selector



- It prepares the working of the machine.
- By shifting the selector forward "▲" the machine moves forward; by shifting the selector backward "▼" the machine moves backward and the reverse acoustic signal is activated. When the selector is in the "0" central position the machine remains in neutral.

38) Display

- See paragraph ("Display controls").

39) Button not in use



40) Suction activation button

- The suction activation is enabled by turning the key (29) to the "ON" position.
- Press the "" button (40) to start the suction, on the display the symbol "" will light up and, if the forward motion is engaged or if the machine is in neutral, the squeegee drops.
- Press the (40) button again and the "" suction will stop and the squee-



geeg lifts.

- If the machine is still, the squeegee is lowered and the key (29) is on "ON" after a certain period of inactivity the squeegee will automatically lift.

42) Silent operation button



Pressing the button (42) "" reduces the speed of the intake turbine, which considerably reduces the machine noise; the symbol "" appears

on the display with the function enabled.

Pressing again button (42) "" turns off the function and the machine will start to operate again in standard mode; symbol "" appears on the display.

 **NOTE:**

When turning off the aspiration turbine with "silent operation" mode enabled, the operation of the turbine will automatically switch to "standard operation" mode for the entire shut-off delay time.

- 43)  Brush unit button (ON/OFF)**
- The activation of the brush unit is enabled by turning the key (29) to the "ON" position.
 - Press the button (43) to lower the brush unit; the symbol "" on the display will turn on.
 - The brushes start to rotate when pressing the accelerator pedal, they stop when the accelerator pedal is raised.

**NOTE:**

The brushes rotate whether there's the forward motion or the reverse active and even if the machine is still with the potentiometer (30) placed on "0".

- When the machine is still, with the head lowered, the brushes still and the key (29) on "ON" position, after a certain period of inactivity the head will automatically lift.
- If you press the "" button (43) while the brushes are rotating, they'll stop, the unit lifts and the symbol on the display turns off.

44)  Acoustic warning button

- Press the button "" to produce an acoustic warning signal.
- Turn the key (29) to the "ON" position to control its functioning.

45)  Rotating flash lights button

- When pressed, with the key (29) in the "ON" position, it starts the flash lights.



46)  Operating lights button



- When pressed, with the key (29) in the "ON" position, it turns on the operating lights.

47)  Water supply button



- The water supply is activated when the key (29) is on "ON" position, the (43)



"" button is inserted and when the accelerator pedal is pressed.



- Press (47) "" button, on the display the symbol "" appears, and the water electrovalve opening is prepared. Its functioning is controlled by the pressed accelerator pedal.

Repeatedly press the "" button (47) to increase the water quantity; when the maximum quantity is reached, it'll be shown on the display by the "" symbol, if the "" button (47) is pressed again the function will be disabled.

48)  Chemical agent dispenser button

- The chemical agent supply is activated by the key (29) in "ON" position, by the buttons (47) "" and 43 "" inserted and by the pressed accelerator pedal.

- Press the "" button (48), on the display the symbol "" appears, and the chemical agent dosage is prepared. The dosing pump functioning is controlled by the pressed accelerator pedal.

Repeatedly press the "" button (48) to increase the chemical agent quantity; when the maximum quantity is reached, shown on the display by the "" symbol, press the "" button (48) again to disable the function.







NOTE:

In case of emptying of the chemical agent dosing plant, after changing the tank by keeping the “” button pressed for at least “5” seconds, the air purging procedure is activated for about 40 seconds; this function only activates when the machine is still, the key (29) on “ON” position and the gear selector (31) is in neutral.

50)  ECO button

- Press the “” button (50) the water, chemical agent, suction and head pressure parameters assume the following values:
 - Water flow = 3[^] mark.
 - Chemical agent = position 1 (0,2%).
 - Suction = silent mode (50%).
 - Lowered brushes pressure = minimum pressure.

51) Brushes pressure adjustment

- When the head is lowered it's possible to adjust the lowered brushes pressure in three positions:
 - **Minimum pressure=**
on the display appears the following symbol “”.
 - **Medium pressure=**
on the display appears the following symbol “”.
 - **Maximum pressure=**
on the display appears the following symbol “”.
- By pressing the “” button (51a) you can increase the value; by pressing the “” button (51b) you can reduce the value.



NOTE:

Each time the head group lifts (rest position), the brushes pressure sets at the minimum value.



NOTE:

This function is equipped with a safety system that automatically recognises an excessive current absorption of the brushes motors and it's able to automatically change the lowered brushes pressure taking it to the most useful position.

6.1.b - Accelerator pedal (Fig. 10)

- Pressing the accelerator pedal (7), the machine moves forward or backward, depending on the direction selector position.
- Release the accelerator pedal (7) to slow down the machine until it stops. After a few seconds after the machine is still the parking brake automatically activates; this brake will be disabled when the accelerator pedal (7) is pressed with forward or reverse motion on.

7.1 DISPLAY (Fig. 9)

The control dashboard has a display (38) that lights up when turning the start key on “ON” position.

The following pictograms appear on the display:

“A”  = Battery



Indicates the battery charge status;

“A1”  = battery charged;

“A2”  = battery discharged.





 = Aspirator operating

This appears on the display when selecting the button (40) “” indicating that the aspirator is operating; when repressing the

button (40) "" to stop operation, the pictogram "" when the aspirator stops.

"" = **Silent operation**

Vacuum in operation.



It will be shown on the display when the "" button (42) is pressed, indicating that the suction is working with a reduced rpm; by pressing the "" button (42) again, the symbol "" disappears and the symbol "" is shown, activating the normal functioning.

"" = **Water dispensing presetting**

On the display is shown when you select the "" button (47) indicating that the water supply electrovalve is active.

"" = **Brush rotation presetting**

On the display is shown when you select the "" button (43) indicating that the brush

rotation is active; by pressing the "" button (43) again the brush rotation motor is disabled, the pictogram "" disappears and the head lifts.

"" = **Maximum liquid level in recovery tank**

This displays when the fluid in the recovery tank has reached the maximum level.

"" = **Clean water tank empty**

Is shown flashing when the clean water tank reached the minimum level; the machine keeps working anyway.

The indicator stops only in presence of the following conditions:

- full tank;
- after a few seconds after reusing the machine.

"" = **ECO mode**

Is shown when the ECO function is active through the "" button (50).

"" = **Accelerator pedal pressed**

This symbol inserts when the machine starts indicating a wrong starting operation sequence, to remove the alarm release the accelerator pedal (7) (Fig. 10).

"" = **Chemical agent dosing button**

Is shown on the display when the "" button (48) is pressed indicating the quantity of measured chemical agent, with the dosage % at its side:



- The settable percentages are:
0,3% - 0,5% - 1% - 2% - 3%.

8.1 PARAMETER SETTING (Fig. 9)



The operator can access the menu to set the following parameters:

Language;
Battery type;
Brightness / contrast.

Proceed as follows to access the menu:

- Press and keep pressed the "" (47) and "" (42) buttons, then turn the starting key (29) to start the machine until the following display is shown:



- Release the pressed keys.
- Insert the Password by pressing the "" or "" buttons (51) until on the display is shown the number "10".

- Press the button (48) “” to confirm the password and enter the parameter setting menu; the following screen appears:



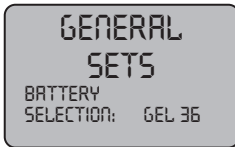

- To browse the parameter setting menu, press the button (47) “” and the following screens will appear in succession:



8.1.a - Language setting

- Enter the parameter setting menu until the following screen appears:





- Choose the language using the “” or “” buttons (51), then press the “” button (48) to confirm.

8.1.b - Battery type setting

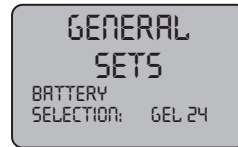
- Enter the parameter setting menu until the following screen appears:



- Choose the type of battery using the “” or “” buttons (51), then press the “” button (48) to confirm;

GEL = Gel battery
AGM = AGM battery
WET = ACID battery

8.1.c - Brightness and contrast setting

- Enter the parameter setting menu until the following screen appears:



- Choose the type of display brightness by setting a value from “0 to 30” using the “+” or “-” buttons (51), then press the “⌂” button (48) to continue to the contrast setting.



- Choose the type of display contrast by setting a value from “5 to 50” using the “+” or “-” buttons (51), then press the “⌂” button (48) to confirm.

8.2 EMERGENCY (Fig. 8)

In case of emergency pull the plug (26) out of the socket (5); to disconnect power to the circuits and to stop all the functions of the machine



WARNING:

Unplug (26) the machine while it is functioning only if absolutely necessary; do not follow this procedure to turn off the machine as it may cause serious damage to it.

8.3 - SAFETY DEVICES (Fig. 11)



WARNING:

The machine is equipped with an operator presence sensor (41) this sensor blocks all of the machine's functions and sets the machine in neutral whenever no operator is present in the driver's seat.

8.4 - ALARMS DURING THE FUNCTIONING (Fig. 9)

If the machine malfunctions, the display (38) will indicate the alarm type, according to the following list.

In order to restore the machine's proper functionality, consult the list below and perform the recommended procedures.

If the recommended actions should not resolve the problem, contact Technical Assistance.

Alarm	Meaning	Solution
AL_1: Function Brush Amp.	Brush amperometric protection	Check the brush operating mode. High brush motor working current detected.
AL_2: Function Aspirator Amp.	Aspirator amperometric protection	Check aspirator motor absorption. High aspirator motor working current detected.
AL_3: Function Power failure	Power stage damaged	Damaged aspirator or brush power stage: replace card.
AL_4: Function Overcurrent	Overcurrent on brush or aspirator outputs	Short circuit detected on brush or aspirator motor output: check connections and motor state.
AL_5: Function Overtemperature	Thermal protection on brush/aspirator stage	Brush and aspirator power stage overheating: check absorption.
AL_6: Function Act1:endsw fail	Brushes actuator limit switch reading anomaly	Anomalies in the limit switch configuration. Check the brushes actuator limit switches connections and status.
AL_7: Function Act2:endsw fail	Wiper actuator limit switch reading anomaly	Anomalies in the limit switch configuration. Check the wiper actuator limit switches connections and status.
AL_8: Function Act1:timeout	Brushes actuator: final position not reached	Brushes actuator position not reached within the maximum expected time. Check the actuator connections and/or possible mechanical obstacles.
AL_9: Function Act2:timeout	Squeegee actuator: final position not reached	Squeegee actuator position not reached within the maximum expected time. Check the actuator connections and/or possible mechanical obstacles.

Alarm	Meaning	Solution
AL_13: Traction Pedal failure	Pedal tearing	Check the pedal potentiometer connections and status.
AL_14: Traction Release Pedal	Pedal pressed during ignition	Close running micro during ignition detected: release the pedal.
AL_15: Traction Overtemperature	Thermal protection on traction stage	Traction power stage overheating: check absorption.
AL_16: Traction Power failure	Traction power stage damaged	Damaged traction power stage: replace card.
AL_17: Traction Overcurrent	Overcurrent on traction output	Short circuit detected on traction motor output: check connections and motor state.
AL_18: Traction Traction Amp.	Traction amperometric protection	Check the traction operating mode. High traction motor working current detected.
AL_20: General EEPROM failure	Inner memory card error	Replace card.
AL_21: General key-off failure	Wrong key sequence	Rebound on the key signal detected: check the key contact connections and status.
AL_22: General Main relay	Main relay damaged	The main relay on the card appears damaged: replace the card.
AL_23: General Overvoltage	Overvoltage	Overvoltage on function card detected. Check the battery connections.
AL_24: Traction Batt Connection	Battery not connected to the function card	Check the traction operating mode. High traction motor working current detected.
AL_25: General Key connection	No control panel-function communication	Check connections between the keypad card and functions.

9.1 - FILLING THE TANK (Fig. 1-12)



WARNING:

Only add clean mains water to the tank at a temperature no greater than 50°C.

- Check that the hose (17) is properly connected to the tank by means of the appropriate joints.
- Open the clean water tank (13) cap (14).
- Pour water into the tank (13) until it is full.
- Close the cap (14) when the filling procedure is completed.

9.2 - DETERGENT/ CHEMICAL TANK (Fig. 13)



NOTE:

Use non-foamy detergents only. For the quantities, follow the instructions provided by the detergent manufacturer according to the type of dirt.



DANGER:

- In the event of eye or skin contact with the detergent, or ingestion of the detergent, see the detergent manufacturer's usage and safety data sheet.
- Lift the lever (52) to unlock the cover (53), then lift it.
- Check that in the tank (54) there's the product necessary for the working day.

In case of tank replacement work as indicate below:

- Remove the cap (55), extract the tank (54) and insert a new 5 litres one then insert the cap (55) using the small suction pipe.



NOTE:

The tanks (54) to use are the standard 5 litres type which can be found on the market.

- Close the cover (53) and block it with the coupling (52).
- Perform the air purging procedure (described in this manual).

10.1 - OPERATION (Fig. 1-7-9)

10.1.a - Checks before use

- Check that the recovery tank's drainage tube (15) is properly connected and sealed.
- Check that the squeegee's water suctioning tube (16) is properly inserted into the recovery tank.
- Check that the coupling (56) on the squeegee (20) is not obstructed and that the tube is properly connected.
- Check the charge status of the batteries by turning the key (29) to its "ON" position and checking the charge indication on the display (38).

10.1.b - Preparing the machine and choosing the cycle (Fig. 9-10)

- Sit on the driving position.

Working cycle:

- The machine can perform 4 working cycles:

Drying only cycle:

- To perform only the drying cycle press the  button (40 Fig. 9), the aspirator activates.

Brushing only cycle:

- To perform only the brushing cycle press

the  button (43 Fig. 9), the brushes rotation is prepared.

Brushes rotation starts when the machine, with the accelerator (7 Fig. 10) pressed, starts moving forward or backward, or with the accelerator pressed and a potentiometer (30) turned on "0".

Washing, brushing cycle:



- Press the button  (43 Fig. 9) to prepare brushes rotation and press the but-

ton “” (47 Fig. 9) to prepare water supply.

Brushes rotation and water supply start when the accelerator pedal is pressed with forward or backward motion, or if the machine is off and the potentiometer (30 Fig. 9) turned on “0”.

The gear selector must be always engaged.

Washing, brushing, drying cycle:

- Press the button “” (47 Fig. 9) to prepare water supply;
- press the button “” (43 Fig. 9), brushes rotation is prepared which start when pressing the accelerator pedal with forward motion engaged;
- press the button “” (40 Fig. 9), the aspirator starts.

10.1.c - Using the machine (Fig. 9)



DANGER:

Be extremely careful when using the machine on ramps in order to avoid roll over or situations which may cause the machine to lose its balance.



DANGER:

Avoid sudden sharp turns. Turn the wheel from lock to lock only at low speed, always considering ground conditions.

- After having started the machine and chosen the type of cycle, select the desired movement direction using the selector (31 Fig. 9).
- Turn on the rotating flash lights (10 Fig. 1) and the operating lights (9 Fig. 1).
- Use the accelerator (7 Fig. 10) to begin the cleaning operations.



NOTE:

Release the accelerator to stop the rotation of the brushes and the dispensing of water.



NOTE:

Proper floor cleaning and drying is performed by driving the machine forwards. When driving in reverse, the squeegee is raised and the suction unit, for removing the water from the floor, is deactivated.

- Adjust the washing solution quantity with the button “” (48 Fig. 9) if its necessary.
- Check the charge status of the batteries on the display (38 Fig. 9).



NOTE:

When the operator gets out of the machine the parking brake automatically activates.



DANGER:

It is forbidden to park the machine on ramps.

10.1.d - End of use and shutdown (Fig. 9)

- Once all of the cleaning operations have been completed, shut off, in sequence, the rotation of the brushes and the suction unit, using the relative controls according to the type of cycle being employed.
- Turn the key (29 Fig. 9) to its “OFF” position.
- The parking brake automatically activates.
- Empty and wash out the recovery tank and the solution tank as indicated in the relative sections.

11.1 - DRAINING THE RECOVERY WATER (Fig. 14)



DANGER:

Before lifting the recovery water tank (11) make sure it is empty.

At the end of the washing cycle or when the recovery water tank (11) is full, it is necessary to empty the tank by proceeding as follows:



N.B.:

To dispose of the recovery water, comply with the standards in force in the country in which the machine is used.

- Position the machine near to a drain outlet.
- Disconnect the hose (15) from the support.
- Remove the cap (57) from the hose (15) and drain all the water contained in the tank.



N.B.:

The amount of water that comes out can be modulated by pressing on the end of the tube (15).

- Put the cap (57) back on the hose (15) and reposition it on the relative support.

12.1 MAINTENANCE AND CLEANING



WARNING:

For information and warnings related to maintenance and cleaning operations please follow what is indicated in the "Safety warnings for floors washer-dryer" annexed to this one.

OPERATIONS TO PERFORM DAILY

12.1.a - Emptying and cleaning the clean water tank (Fig. 15)



WARNING:

At the end of the washing operations, it is compulsory to drain and clean the clean water tank (13) to prevent deposits or scaling.

After draining the recovery water tank, drain the clean water tank (13) as follows:

- Position the machine over a drain outlet.
- Remove the hose (17) from the holding hooks and lay it down on the drain outlet; remove the cap (57) and drain all the water contained in the tank.
- Wash the inside of the tank, leaving the drain hose open and adding clean water through the top opening.
- Once finished cleaning, lift the tube (17), close it with its appropriate cap (57) and position it within its appropriate lodgings.

12.1.b - Cleaning the recovery water tank (Fig. 16)



WARNING:

At the end of the washing operations, it is compulsory to clean the recovery water tank to prevent deposits or scaling and the proliferation of bacteria, odours or mould.



DANGER:

Drain the recovery water tank (11) before lifting it.

- Remove the cover (12).
- Lift the recovery water tank (11).
- Leaving the hose (15) lowered and the cap off, add water through the upper opening (58), cleaning the inside of the tank until clean water comes out of the

drain hose.

- Reassemble all of the parts by performing these operations in the opposite order.
- Remove and clean the suction filter (59) with running water, removing possible pieces of paper, wood etc... which obstruct it.

12.1.c - Cleaning the wiper (Fig. 17)

In order to clean the squeegee correctly (20), it is necessary to remove it as follows:

- Disconnect the hose (16) from the squeegee (20).
- Loosen the knobs (36) and remove the squeegee (20).
- Wash the squeegee and in particular the rubber blades (60) and the inside of the aspiration connector (56).



NOTE:

If, during washing, it is clear that the rubber blades (60) are damaged or worn, it is necessary to replace them or turn them over.

- Replace all the components in reverse order.

12.1.d -Cleaning the side skirts (Fig. 18)

To make a proper cleaning of side skirts (61) lift and wash the gums (62).



NOTE:

If, during washing, it is clear that the rubber blades (62) are damaged or worn, it is necessary to replace them or turn them over.

- Lower the side skirt (61).



DANGER:

Do not lift the side skirts with the casing (63) removed.

OPERATIONS TO BE PERFORMED EVERY 3 MONTHS



12.1.e - Check the wear status of the steering chain (Fig. 19)

- Check the wear and corrosion status of the chain (66) found beneath the machine near the front wheel. If the chain appears corroded, it must be replaced.
Contact the technical assistance service.

OPERATIONS TO PERFORM WHEN NECESSARY

12.1.f - Replacing the brushes (Fig. 20)

The brushes must be replaced whenever they appear worn or whenever their bristles are shorter than 2 cm. They must also be replaced based on the type of flooring to be cleaned; in order to replace them, perform the following operations:

- Insert a hand beneath the brush support unit (19). In order to detach the brush, turn it quickly and forcefully in the opposite direction from that in which it rotates during normal function.
- Place the new brushes beneath the brush support unit (19).
- Get into the driver's seat and turn the key (29 Fig. 9) to its "ON" position.
- Engage a movement direction.
- Press the  (43 Fig. 9) button to enable brush rotation; the brush unit will be lowered.
- By pressing the accelerator pedal (7 Fig. 10), the brush support flanges begin to turn, thereby connecting with the brushes. Then, release the pedal.
- Press the  (43 Fig. 9) button again and turn the key (29 Fig. 9) to its "OFF" position.

12.1.g - Cleaning the clean water filter (Fig. 21)

- Make sure that the tank (13) is empty.
- Remove the cap (22) and take out the filter cartridge (64).
- Clean the filter cartridge (64) using running water.
- Reassemble everything proceeding in reverse making sure that the gasket (65) is placed correctly.

12.1.h - Replacing the squeegee rubber blades (Fig. 22)

When it becomes clear that drying the floor is difficult or traces of water remain on the floor, it is necessary to check the wear on the squeegee rubber blades (20):

- Remove the squeegee unit (20) as indicated in the "Cleaning the squeegee" paragraph.
- Loosen the finned nuts (67) and remove the rubber blades (60).



NOTE:

When the rubber blades (60) are worn on one side, on one occasion they may be turned over.

- Replace or turn over the rubber blades (60) without inverting them.
- Replace all the components in reverse order.



NOTE:

Two types of rubber are available:
Para rubber for all types of flooring and polyurethane rubber for workshop floors with oily residues.

12.1.i - Replacing the side skirt rubbers (Fig. 23)

When it becomes clear that the washing water is not well held by the side skirts, it is necessary to check the wear status of the rubbers (62):

- Remove the side skirts as indicated in the "Cleaning the side skirts" paragraph.
- Unscrew (68) and remove the rubbers (62).



NOTE:

When the rubber blades (62) are worn on one side, on one occasion they may be turned over.

- Replace or turn over the rubber blades (62) without inverting them.
- Replace all the components in reverse order.

12.1.j - Adjusting the pressure of the squeegee (Fig. 24)

- Start up the machine and press the (40 Fig. 9) "" button.

The wiper unit will be lowered.

- Engage the forward motion and move by a few meters, then get out of the machine.
- Use the threaded bar (69) to adjust the squeegees' (60) contact with the floor. Turn it clockwise for increased contact and counter clockwise for less contact.



NOTE:

When the squeegee is making proper contact with the floor, there will be no streaking on the floor during machine function and the entire length of the squeegee will be in contact with the floor.

12.1.k - Checking the wear status of the three wheels (Fig. 25)

- Check the wear status of the three wheels (8) and (23) periodically; if they appear worn or damaged, contact a technical service centre in order to have them replaced.



DANGER:

Operating the machine with worn or damaged wheels poses a danger to the operator as the machine could have less traction when turning.

12.1.l - Replacing the fuses (Fig. 26)



WARNING:

Replace the blown fuse with one with the same amperage.

- To change the fuse (70) on the positive pole of the battery, proceed as follows:



WARNING:

Make sure the recovery tank is empty.

- Pull the plug (26) out of the socket (5).
- Lift the recovery tank (11) using the specific handles (25).

Fuse (70) - 150A

Battery fuse.

Fuse (71) - 10A

Dashboard fuse.

- For the fuse rearmament (71) remove the panel (72) unscrewing the related screws and work on the button (49) to rearm it.

12.1.m -Battery charger configuration (Fig. 27)



WARNING:

The machine comes pre-configured for use with "Sonnenschein" gel batteries.



DANGER:

This operation must be performed only by a qualified technician.

Standard configuration with Sonnenschein gel batteries

- Take off the case (A) of the external battery charger and check that the switches (1 - 2 - 3 - 4) are set to the configuration shown in figure (B).

Perform the following operations to modify the configuration:

Configuration for gel batteries other than the Sonnenschein typology

- Check that the switches (1 - 2 - 3 - 4) are set to the configuration shown in figure (C).

Configuration for acid batteries

- Check that the switches (1 - 2 - 3 - 4) are set to the configuration shown in figure (D).



WARNING:

Only modify switches (1 - 2 - 3 - 4); do not alter the positions of switches (5 - 6 - 7 - 8).

TROUBLESHOOTING

PROBLEM	CAUSE	SOLUTION
The machine does not start up when the key is turned.	Low battery.	Check that the battery is charged.
	Main fuse blown.	Replace the fuse found on the battery cable.
	Defective key.	Change the key.
The brush doesn't turn.	Movement set to neutral.	Engage forward or reverse movement.
	Engine trouble.	Replace engine.
	Faulty board.	Change the board.
The suction unit does not function.	Recovery tank full.	Empty the tank.
	Defective turbine motor.	Change the motor.
	Faulty board.	Change the board.
The machine does dry properly, leaving traces of water on the floor.	Aspirator off.	Start up the aspirator.
	Aspiration tube blocked.	Check and if necessary clean the aspiration tube that connects the squeegee to the recovery tank.
	Recovery tank full.	Empty the recovery tank.
	Squeegee rubber blades worn.	Replace or turn over the squeegee rubber blades.
No water comes out.	Tank empty.	Fill the tank.
	Defective water pump.	Change the water pump.
	Faulty board.	Change the board.
	Filter clogged.	Clean the filter.
	Pump solenoid valve not functioning.	Call technical assistance.

PROBLEM	CAUSE	SOLUTION
The machine does not move in working conditions.	Operator not properly seated in the driver's seat.	Sit properly in the driver's seat.
	Defective monowheel.	Monowheel replacement.
	Movement direction not engaged.	Use the appropriate control to engage the desired movement direction.
	Faulty board.	Change the board.
Insufficient floor cleaning.	Unsuitable brushes or detergent.	Use brushes or detergents which are suitable for the type of floor or dirt to be cleaned.
	Brush worn.	Replace the brush.
The empty solution tank indicator  keeps flashing.	Empty tank.	Fill the tank.
	Tap closed.	Open the tap.
	Faulty flowmeter.	Replace the flowmeter.

Abbreviations:

BATT Battery
CN1 6 pole Display - Board connector
CN2 20 pole Electric board connector
CN3 12 pole Board
CN4 4 pole Board - Display connector
CN6 Batteries connector
CH Ignition key
E.V. Eletrovalve
F1 150A fuse
F2 10A rearmable fuse
FLUS Flowmeter
MA Suction motor
MS1 Brush motor 1
MS2 Brush motor 2
MT Traction motor
PA Water pump
PC Chemical pump
PT Potentiometer
S1 Recovery level Touch sensor
TR Contactor

1.....Display
2.....Power ON
3.....Forward - backward motion
4..... Back
5..... Next
6..... Micro seat
7.....Micro steering angle
8.....Level Touch Cell
9..... Processor 36/12
10..... Brushes actuator
11..... Wiper actuator
12.....Flowmeter
13.....Horn
14..... Headlights
15..... Potentiometer 47k
16..... Flashing lights
17..... Accelerator pedal

WIRING DIAGRAM

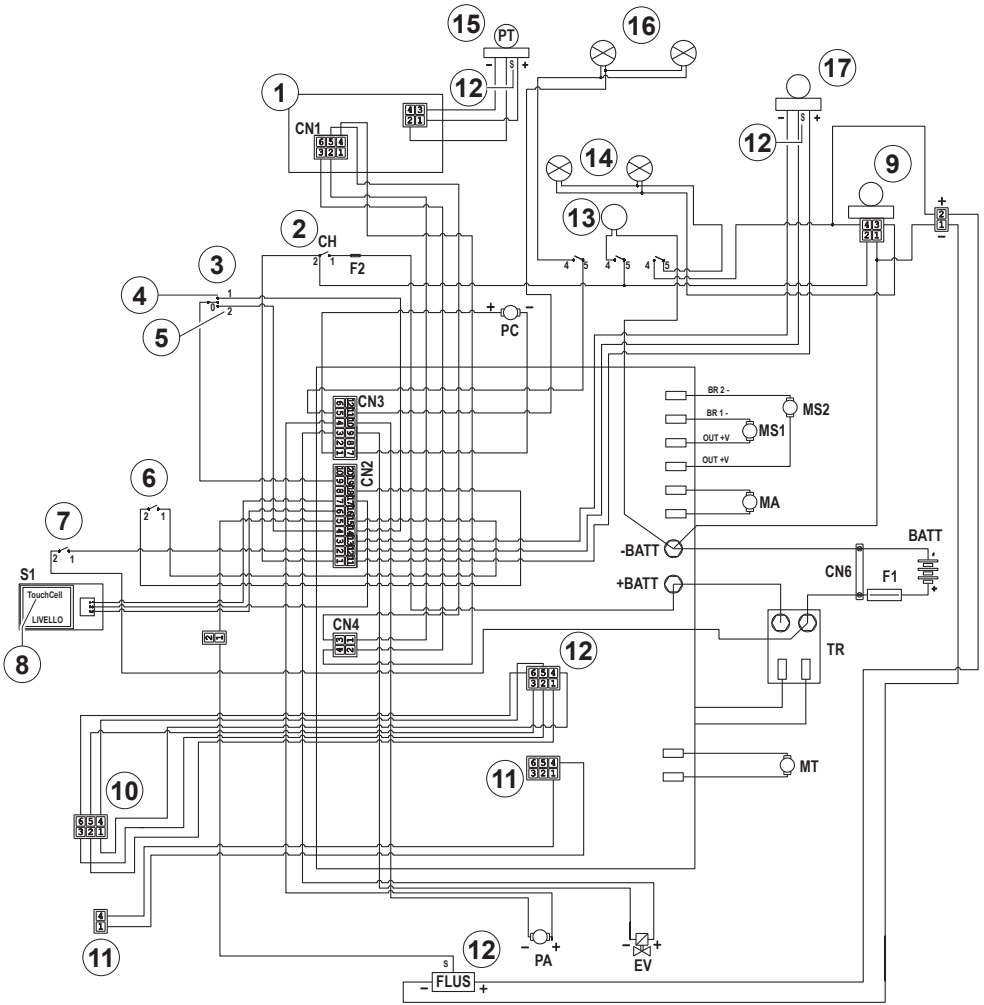

DEALER



Cod. 49.0295.00 - 3^a ed. - 01/2023

GHIBLI & WIRBEL S.p.A.

Registered office:

Via Enrico Fermi, 43 - 37136 Verona (VR) - Italy

Headquarters:

Via Circonvallazione, 5 - 27020 Dorno (PV) - Italy

P. +39.0382.848811 - F. +39.0382.84668 - M. info@ghibliwirbel.com

www.ghibliwirbel.com

100% MADE IN ITALY



ISO 9001

