



FR30
E45 TOUCH



EN Use and Maintenance

CE

49 0219 00
ed. 10-2018

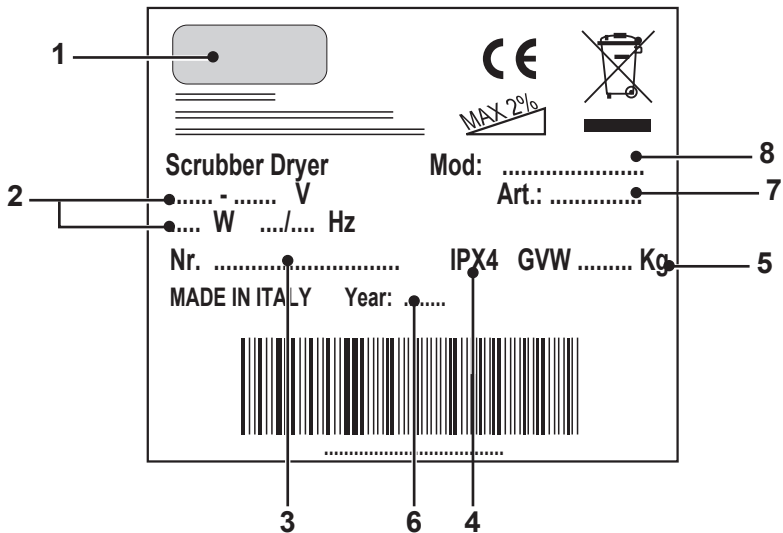
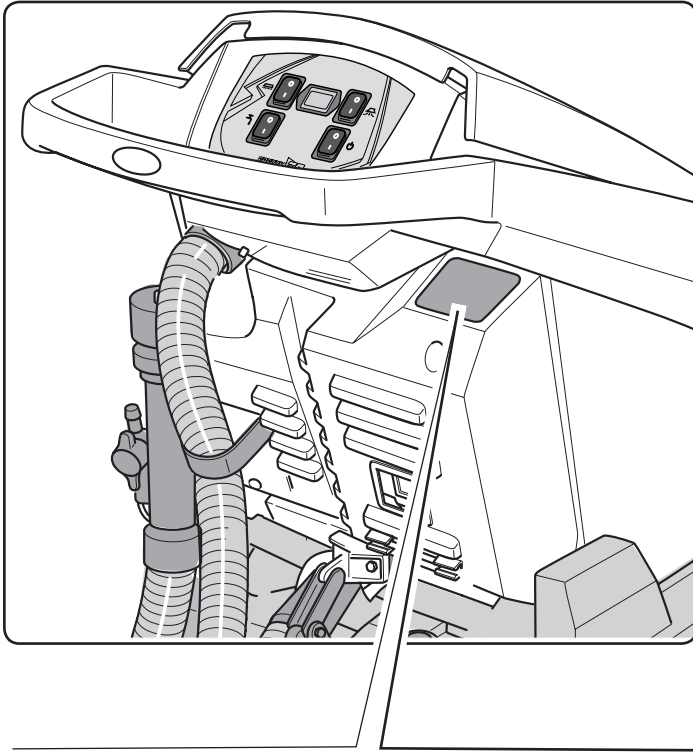

	1	2	3	4	5	6	7	8
IT	Produttore	Caratteristiche elettriche	N° Matricola	Grado di protezione	Peso in ordine di marcia	Anno di costruzione	Codice articolo	Modello
EN	Manufacturer	Electrical characteristics	Serial N°	Degree of protection	Weight in running order	Year of manufacture	Item code	Model
FR	Producteur	Caractéristiques électriques	N° Matricule	Degré de protection	Poids en ordre de marche	Année de construction	Référence de l'article	Modèle
DE	Hersteller	Elektrische Eigenschaften	Matr.Nr.	Schutzgrad	Gewicht bei Betrieb	Baujahr	Artikelnummer	Modell
ES	Fabricante	Características eléctricas	N° Matricola	Grado de protección	Peso en orden de marcha	Año de fabricación	Código del artículo	Modelo
PT	Produtor	Características eléctricas	Número de série	Gráu de protecção	Peso em ordem de marcha	Ano de construção	Código do artigo	Modelo
NL	Productent	Elektrische eigenschappen	Serienummer	Beschermingsgraad	Gewicht in rijklaare bestand	Bouwjaar	Artikelcode	Model
NO	Produsent	Elektriske egenskaper	Matr.Nr.	Grad av beskyttelse	Vekt i kjøreløst stand	Byggeår	Artikkelnummer	Modell
DK	Fabrikant	El-specifikationer	Matrikelnummer	Tæthedsgrad	Vægt i køreløst stand	Byggeår	Artikeltkode	Model
SV	Tillverkare	Elektriska egenskaper	Serienummer	Grad av skydd	Vikt i körløst skick	Byggnadsår	Artikelnnummer	Modell
PL	Producent	Właściwości elektryczne	Nr. Fabryczny	Stopień ochrony	Ciepła w stanie pracy	Rok produkcji	Kod produktu	Model
CS	Výrobce	Elektrické údaje	Výrobné č.	Úroveň ochrany	Hmotnost v provozním stavu	Rok výroby	Kód položky	Model
SK	Výrobca	Elektrické vlastnosti	Výrobné č.	Úroveň ochrany	Hmotnosť v provoznom stave	Rok výroby	Kód položky	Model
TR	Üretici	Elektriksel özellikler	Seri No	Koruma sınıfı	Çalışma halindeki ağırlık	Yapım yılı	Ürün Kodu	Model
HU	Gyártó	Elektronos sajátosságok	Törzskönyvi szám	Védelemi szint	Súly működés közben	Gyártási év	Cikkszám	Modell
RO	Producător	Caracteristici electrice	Nr. Matr.ozil	Grad de protecție	Greutate în stare de funcționare	Anul de construcție	Cod articol	Model
EL	Κατασκευστής	Ηλεκτρολόχο χαρακτηριστικά	Αρ. Μητρώου	Βαθμύς προστασίας	Βάρος στην λειτουργία	Έτος κατασκευής	Κωδικός του άρθρου	Μοντέλο
RU	Изготовитель	Электрические характеристики	Заводской №	Степень защиты	Эксплуатационный вес	Год выпуска	Код изделия	Модель
HR	Proizvođač	Električna svojstva	Registraijski br.	Stepen zaštitčnosti	Težina u momentu rada	Godina proizvodnje	Kod artikla	Model
SR	Proizvođač	Električne karakteristike	Br. * Proizvođača	Stepen zaštitljenosti	Težina u momentu rada	Godina proizvodnje	Šifrovanje proizvoda	Model
BG	Производител	Електрически характеристики	Сериен номер	Степен на защита	Работно тегло	Година на производство	Код на продукта	Модел
ET	Tootja	Elektrilised omadused	Seria number	Määratl kaitse	Kaal töökorras	Ehitamise aasta	Koodetisi artikkel	Mudel
FI	Valmistaja	Sähköiset ominaisuudet	Sarjanumero	Katoliintuokka	Paino ajokunnassa	Rakennusvuosi	Tuotenumero	Maaili
LV	Rādītājs	Elektriskie raksturlielumi	Serijs numurs	Aizsardzības pakāpe	Svars braukšanas kārtībā	Gads būvniecībā	Vienības numurs	Modelis
LT	Gaminiojas	Elektrinės charakteristikos	Elės numeris	Apsaugos laipsnis	Eksploatacinė masė	Statybos metai	Priekės numeris	Modelis
SL	Proizvajalec	Električne značilnosti	Serijska številka	Stopnja zaščite	Teža pripravljenega za rabo	Leto izgradnje	Zaporedna številka	Model
AR	الصانع	الخصائص الكهربائية	الرقم التسلسلي	درجة الحماية	الوزن في وضعية التشغيل	سنة التصنيع	رمز المنتج	النموذج



English ENGLISH - 1
(Translation of original instructions)

Dear Customer,

Thank you for choosing one of our cleaning products.

The floor scrubber dryer that you have purchased has been designed to satisfy the user in terms of ease of use and reliability over time.

We are aware that in order for a good product to stay that way, over time, it requires continuous updates aimed at meeting the expectations of those who use it on a daily basis. For this reason, we hope that you will not only be a satisfied customer but also a partner who does not hesitate to give us your opinions and ideas originating from your personal day-to-day experience.

Indice

Technical data	EN-3
1.1 Introduction	EN-5
2.1 Getting to know the machine	EN-5
3.1 Unpacking	EN-5
3.1.a - Standard machine equipment.....	EN-5
4.1 Assembling the components	EN-5
4.1.a - Wiper assembly	EN-5
4.1.b - Brush assembly	EN-5
5.1 Control panel	EN-6
6.1 Filling the tank	EN-6
7.1 Operation	EN-6
7.1.a - Checks before use.....	EN-6
7.1.b - Electrical connection	EN-6
7.1.c - Preparing the machine and choosing the cycle	EN-7
7.1.d - Using the machine	EN-7
7.1.e - End of use and switching off.....	EN-7
7.1.f - Maximum recovery tank water level alarm	EN-8
8.1 Draining the recovery water	EN-8
9.1 Maintenance and cleaning	EN-8
9.1.a - Emptying and cleaning the clean water tank	EN-8
9.1.b - Cleaning the recovery water tank	EN-9
9.1.c - Cleaning the squeegee	EN-9
9.1.d - Cleaning the clean water filter	EN-9
9.1.e - Replacing the brush	EN-9
9.1.f - Replacing the squeegee rubber blades	EN-10
9.1.g - Cleaning the recovery water tank	EN-10
9.1.h - Replacing the fuses	EN-10
9.1.i - Wiper adjustment.....	EN-10
Troubleshooting	EN-12
10.1 Warranty	EN-13
Wiring diagram	EN-14
FR 30 - FR 45 TOUCH 115 VAC.....	EN-14
FR 30 - FR 45 TOUCH 230 VAC	EN-15

Technical data

Type of use	Operator on ground
Characteristics	
Power supply voltage	See technical data plate
Installed load	850 W
Forward movement	Manual
Washing width *	430 mm
Drying width	650 mm
Brushes / Pad	
Diameter / Number	430mm/17"x1
Motor power / number	450 Wx1
Motor speed	140 rpm
Specific pressure	33 gr/cm ²
Aspiration	
Motor power	400 W
Negative pressure	1189 mmH ₂ O
Air flow rate	28 l / sec
Noise level	63 dB
Tank	
Recirculation	No
Solution capacity	30 l
Recovery capacity	33 l
Dimensions (lxwxh) without wiper	1210 x 560 x 1020 mm
Vibrations ISO 5349 m/sec²	< 2,5
Weight	
Empty weight	70,5 Kg
Weight in running order GVW	100,50 Kg

* The washing width is intended with the machine operating and the brush pressed down.

Accessories	
0.9 ø PPL brush	40.0002.00
Brush spray guard	24.0237.00
Front rubber wiper element	39.0129.00
Rear rubber wiper element	39.0130.00
Optional accessories	
0.7 ø PPL strong brush	40.0102.00
1.2 ø grit 80 tynex brush	40.0202.00
Drive mechanism	40.1007.00
Front anti-oil rubber wiper element	39.0131.00
Rear anti-oil rubber wiper element	39.0132.00

1.1 INTRODUCTION



DANGER:

Before using the machine, carefully read the attached “SAFETY WARNINGS FOR THE FLOOR SCRUBBER DRYER” manual.

2.1 GETTING TO KNOW THE MACHINE (Fig. 1)

- 1) Guide handle.
- 2) Control console.
- 3) Squeegee activation lever.
- 4) Water supply tap.
- 5) Solution tank.
- 6) Tank cover.
- 7) Clean water filling opening.
- 8) Wheels.
- 9) Brush rotation flange.
- 10) Brush.
- 11) Squeegee.
- 12) Recovery water drain hose.
- 13) Squeegee water aspiration hose.
- 14) Recovery water tank.
- 15) Clean water drain/level tube.
- 16) Electric connection plug.
- 17) Clean water filter.
- 18) Brush up/down pedal.
- 19) Brush rotation activation button.
- 20) Touch sensor for starting traction and brush rotation.

3.1 UNPACKING (Figg. 1-2)

Once the packaging has been removed as shown in the instructions on the packaging itself, check that the machine and all the components supplied are intact.

If any evident damage is found, contact the area agent and the carrier within 3 days of receipt.

- Remove the bag (21) containing the accessories.
- Cut the strap (22).
- Remove the wooden blocks (23 and 24).
- Lift the brush flange (9) by pressing down on the pedal (19) (see relative paragraph).

- Lift the wiper support (25) by lifting the handle (3 Fig. 1) (see relative paragraph).
- Position a chute and unload the machine from the bench.

3.1.a - Standard machine equipment (Fig. 3)

The accessories supplied are as follows:

- 10) Brush/brushes.
- 11) Wiper.
- 26) Water filling hose.
- 27) Machine use and maintenance manual.
- 28) Anti-tear hook.
- 29) Fuses.
- 30) Filter for clean water tank opening.

4.1 ASSEMBLING THE COMPONENTS

4.1.a - Wiper assembly (Fig. 4)

- Loosen the two handwheels (31) located on the wiper (11).
- Assemble the wiper (11) on the support (25), tightening the two handwheels (31).
- Connect the tube (13) to the wiper connector (32).



N.B.:

Perform the previous operations with the wiper support lowered.

4.1.b - Brush assembly (Fig. 5)





HAZARD:

Operation to be performed by two people!

- Lift the brush rotation flange (9) slightly and remove the polystyrene protection (33).
- Assemble the brush as described in the paragraph “replacing the brush”.

5.1 CONTROL PANEL (Fig. 9)

20) Sensor for starting brush/es rotation • (for model with traction)

Acting on the sensor (20) with the switch pressed (34) “”, the switch (38) “” and the switch (39) “” pressed, it starts the brush / brushes rotation and water delivery.

34) Main switch

Pressed on position “I” it lights up and gives power to the machine.
Pressed on “0” it stops.

35) Suction unit activation switch

The operation of the switch is enabled by the switch (34) in position “I”.
With the switch in its “I” position, press it down. The switch will light up and the suction unit will activate.

37) Operating hour indicator

Indicates the machine operating hours.

38) Brush rotation enabling switch

This switch can be enabled by turning the key (36) to its “1” position.
Pressing the switch (38) enables brush rotation; its operation is controlled by the lever (20); the button lights up when the brushes rotate.

39) Water solenoid valve switch

The operation of the switch is enabled by the switch (38) in position “I”.
Pressing the switch (39), it prepares the opening of the water solenoid valve, the operation thereof is controlled by the sensor (20); with the valve open, the switch lights.
Use the tap (4) to adjust the quantity of water.

4) Water quantity adjustment tap

Turn the tap (4) counter-clockwise to increase the quantity of water or turn it clockwise to decrease it.

6.1 FILLING THE TANK (Fig. 7)



WARNING:

Only add clean mains water to the tank at a temperature no greater than 50°C.

- Remove the hose (26) supplied, connect one end (26a) to a tap and insert the other end (26b) in the tank (5).
- Check that the tap (40) is open.
- Turn on the tap and fill the tank (5).
- The level of water contained in the tank is displayed on the transparent tube (15).
- Pour the detergent fluid in the tank.



N.B.:

Use non-foamy detergents only. For the quantities, follow the instructions provided by the detergent manufacturer according to the type of dirt.



DANGER:

If the detergent comes in contact with the eyes and/or skin or if swallowed, refer to the use and safety information booklet provided by the manufacturer of the detergent.

7.1 OPERATION (Fig. 8)

7.1.a - Checks before use

- Check that the exhaust tube (12) of the recovery tank is properly coupled and properly sealed.
- Check that the connector (41) on the squeegee (11) is not blocked and that the hose is connected correctly.
- Check that the clean water exhaust tube (15) is correctly coupled to the supports and that the tap (40) is open.

7.1.b - Electrical connection

- Introduce the cable (42) of an extension in the tear-proof hook (28) locking it as shown in figure.
- Connect the outlet (43) of the extension cord (42) with the plug (16) of the machine.
- Connect the power cord to an outlet having minimum capacity of 10A.



WARNING:

- **Make sure that the mains system is equipped with an RCD (circuit breaker).**
- **Unwind the electric power cable completely before operating the appliance.**
- **Use an electrical extension lead only if in perfect condition; ensure that the section is appropriate for the appliance power rating.**
- **Never let the power cable run over sharp edges and do not tread on it.**

7.1.c - Preparing the machine and choosing the cycle (Figg. 6-9)

- Press the switch (34).
- Release the lever (3 Fig. 9) and lower it; the floor squeegee (11 Fig. 9) is lowered.
- Press down on the pedal (19 Fig. 9), release it from its coupling and lift it, the brush (10 Fig. 9) will be lowered.

Working cycle:

- The machine can perform 4 working cycles:

Drying only cycle:

- In order to perform the drying cycle alone, press the switch (35). The suction unit will activate.

Brushing only cycle:

- To perform only the brushing cycle, press the switch (38) to enable brush rotation. Touch the sensor positioned on the handle, to start the rotation of the brush / brushes.

Washing, brushing cycle:

- Press the switch (38) to enable brush rotation, press the switch (39) to enable water dispensing. Touch the sensor positioned on the handle, to start the rotation of the brush / brushes and water supply.

Washing, brushing, drying cycle:

- Press the switch (35) to start the aspirator, switch (38) to enable brush rotation and press the switch (39) to enable water dispensing. Touch the sensor positioned on the handle, to start the rotation of the brush / brushes and water supply.

7.1.d - Using the machine (Fig. 1)

- After turning the machine on and selecting the cycle, the cleaning operation starts, pushing the machine with the help of the handle (1).



N.B.:

Pay attention to particularly delicate floors: do not use the machine while it's stopped and the brush rotation on.



N.B.:

The proper cleaning and drying of the floor is done by pushing the machine forwards; if you go backwards the machine will not perform drying; in this phase, always lift the wiper to avoid damaging the blades.

- If necessary, adjust the quantity of washing water using the tap (4 Fig. 1).

7.1.e - End of use and switching off (Figg. 6-10)

- Once the cleaning operations have been completed, do not shut off the machine immediately: use switches (39) and (38) to deactivate water dispensing and brush rotation.
- Lift up the brush by pressing the pedal (19 Fig. 10) as far as it will go, fitting it in the designated slot.
- Continue with the aspirator inserted to aspirate all the liquid on the floor, then

turn off the aspirator by pressing the switch (35 Fig. 6).

- Lift the squeegee (11 Fig. 10) by lifting the lever (3 Fig. 10).



WARNING:

Always lift the wiper and the end piece after finishing the cleaning operations because this avoids the deformation of the rubber blades and of the brush hairs.

- Press the switch (34 Fig. 6) on "0" to turn off the machine.
- Disconnect the plug from the socket.

7.1.f - Maximum recovery tank water level alarm (Fig. 11)

If during use of the machine, the vacuum cleaner turns off, it means that the level of liquid in the recovery tank has reached the maximum level.

Go to the water drainage station and drain the recovery tank as shown in the relative paragraph.



NOTE:

For the proper operation of the level sensors it is required to properly clean the inside of the tank (14 Fig. 14).

8.1 DRAINING THE RECOVERY WATER (Fig. 12)

At the end of the washing cycle or when the recovery water tank (14) is full, it is necessary to empty the tank by proceeding as follows:



N.B.:

To dispose of the recovery water, comply with the standards in force in the country in which the machine is used.

- Position the machine near to a drain outlet.
- Disconnect the hose (12) from the support.

- Remove the cap (43) from the hose (12) and drain all the water contained in the tank.



N.B.:

The amount of water that comes out can be modulated by pressing on the end of the tube (12).

- Put the cap (43) back on the hose (12) and reposition it on the relative support.

9.1 MAINTENANCE AND CLEANING



WARNING:

All maintenance operations must be performed with the machine off and tanks empty.

OPERATIONS TO PERFORM DAILY

9.1.a - Emptying and cleaning the clean water tank (Fig. 13)



WARNING:

At the end of the washing operations, it is compulsory to drain and clean the clean water tank (5) to prevent deposits or scaling.

After draining the recovery water tank, drain the clean water tank as follows:

- Position the machine over a drain outlet.
- Disconnect the tube (15) from the hooks, close the tap (40), lower the tube to the ground on the drain outlet, open the tap (40) and let the water drain completely.
- Wash the inside of the tank, leaving the drain hose open and adding clean water through the top opening.
- When cleaning is complete, lift the tube (15), leaving the tap (40) open; couple the tube in its recesses.

- To completely drain the water from the tank (5) disconnect the tube (44) from the quick connector (45) then turn the connector downwards, letting the water drain completely; or remove the filter cover (46).

9.1.b - Cleaning the recovery water tank (Fig. 14)



WARNING:

At the end of the washing operations, it is compulsory to clean the recovery water tank to prevent deposits or scaling and the proliferation of bacteria, odours or mould.

- Drain the recovery water as shown in the relative paragraph, positioning the machine over a drain outlet.
- Remove the cover (6).
- Leaving the hose (12) lowered and the cap off, pour water into the tank (14) through a hose, cleaning it until clean water comes out of the drain hose.
- Replace all the components in reverse order.

9.1.c - Cleaning the squeegee (Fig. 4)

In order to clean the squeegee correctly (11), it is necessary to remove it as follows:

- Disconnect the hose (13) from the squeegee (11).
- Loosen the knobs (32) and remove the squeegee (11).
- Wash the squeegee and in particular the rubber blades (47) and the inside of the aspiration connector (32).



N.B.:

If, during washing, it is clear that the rubber blades (47) are damaged or worn, it is necessary to replace them or turn them over.

- Replace all the components in reverse order.

OPERATIONS TO PERFORM WHEN NECESSARY

9.1.d - Cleaning the clean water filter (Fig. 15)



NOTE:

Before cleaning the filter, make sure the clean water tank is empty.

- Unscrew and remove the cover (46).
- Remove the filter (17) and wash it in running water.
- Refit the filter (17) in its seat, then tighten the cover (46).

9.1.e - Replacing the brush (Fig. 6-16)

It is necessary to replace the brush when it is worn more than 2 cm or it must be replaced depending on the type of floor to be washed; to replace it proceed as follows:

- Lift up the brush using the pedal as shown in the relative paragraph.
- Insert a hand under the brush holder unit (9 Fig. 16); to release the brush, turn it abruptly in the direction of rotation.
- Replace the brush, coupling it manually to the brush holder flange (9 Fig. 16).
- Lower the brush-holder flange (9 Fig. 16) using the pedal, as shown in the relative paragraph.
- Press switch (34 Fig. 6) to position "1".
- Press the switch (38 Fig. 6) to enable the rotation of the brushes.
- Adjust the sensor (20) located on the handle to start brush rotation.
- Turn off the machine by pressing the switch (34 Fig. 6) on "0".

9.1.f - Replacing the squeegee rubber blades (Fig. 17)

When it becomes clear that drying the floor is difficult or traces of water remain on the floor, it is necessary to check the wear on the squeegee rubber blades (47):

- Remove the squeegee unit (11) as indicated in the "Cleaning the squeegee" paragraph.
- Press the locking device (48) and open the handle (49).
- Remove the two rubber mounting strips (50) and remove the outer rubber (51).
- Loosen the two turnbuckles (52) and remove the locking bar (53) and the inside rubber (54).



N.B.:

When the rubber blades (51) or (54) are worn on one side, on one occasion they may be turned over.

- Replace or turn over the rubber blades (51) or (54) without inverting them.
- Replace all the components in reverse order.



N.B.:

It is possible to have two types of rubber blade.

Para rubber blades for all types of floor and polyurethane rubber blades for mechanical workshop floors which are dirty with oil.

9.1.g - Cleaning the recovery water tank (Fig. 18)

Remove the upper cover to access inside the recovery water tank.

- Loosen the knob (55) and remove the filter (56).
- Wash the filter (56) with running water and replace it in the machine, tightening the knob (55).

9.1.h - Replacing the fuses (Fig. 8-19)



WARNING:

Replace the blown fuse with one with the same amperage.

- Remove the plug (16 Fig. 8) from the socket (43 Fig. 8).
- Remove the cover (57 Fig. 19) unscrewing the screws (58 Fig. 19) to access the fuse.
- Refit the cover (60 Fig. 19) and the cover (57 Fig. 19).

9.1.i - Wiper adjustment (Fig. 20)

- It is possible to adjust the height of the wiper and adjust the incidence of the blades on the floor.

Height adjustment

- Lower the wiper, using the lever.
- Loosen the screw (65) and lift or lower the wheel (65a) until the wiper is in the desired position, then tighten the screw (65).

Incidence adjustment

- Lower the wiper, using the lever.
- Start the aspirator and proceed for a few metres, then turn off the aspirator and stop the machine.
- Check the incidence of the rubber (47) blades.

Fig. A = too low

Fig. B = too high

Fig. C = correct position

- Use the grey knob (66) for adjustment, turning it anticlockwise to increase the incidence and in the other direction to decrease it.

TROUBLESHOOTING

PROBLEM	CAUSE	SOLUTION
Pressing the switch (34), the machine will not turn on.	Circuit switch to position "0".	Press the power switch.
	Power cable disconnected.	Connect the cable.
The brush does not rotate.	Function card damaged.	Replace.
	The touch sensor on the handle is defective.	Replace.
	Brush motor damaged.	Replace.
	Brush rotation enabling switch not pressed.	Press the switch.
Aspirator does not work.	Function card damaged.	Replace.
	Intake motor damaged.	Replace.
	Suction unit switch not pressed.	Press the switch.
	Recovery tank full.	Empty, wash and clean the tank and the probes.
The machine does not dry well, leaving traces of water on the floor.	Aspirator off.	Start up the aspirator.
	Aspiration tube blocked.	Check and if necessary clean the aspiration tube that connects the squeegee to the recovery tank.
	Dirty wiper.	Clean the wiper.
	Recovery tank full.	Empty the recovery tank.
	Dirty water filter clogged.	Clean the filter.
	Squeegee rubber blades worn.	Replace or turn over the squeegee rubber blades.

PROBLEM	CAUSE	SOLUTION
No water comes out.	Tank empty.	Fill the tank.
	Solenoid valve enabling switch not pressed.	Press the switch.
	Tap turned off.	Open the tap
	Filter blocked.	Clean the filter.
	Solenoid valve does not work.	Call the technical support service.
Insufficient floor cleaning.	Unsuitable brushes or detergent.	Use brushes or detergents which are suitable for the type of floor or dirt to be cleaned.
	Brush worn.	Replace the brush.

10.1 WARRANTY

During the warranty period all defective parts will be repaired or replaced, free of charge. All parts affected by tampering or misuse will be excluded from the warranty. In order to enable the warranty procedure please contact your dealer or a relevant service center by presenting the valid purchase documents.

WIRING DIAGRAM

FR 30 - FR 45 TOUCH 115 VAC

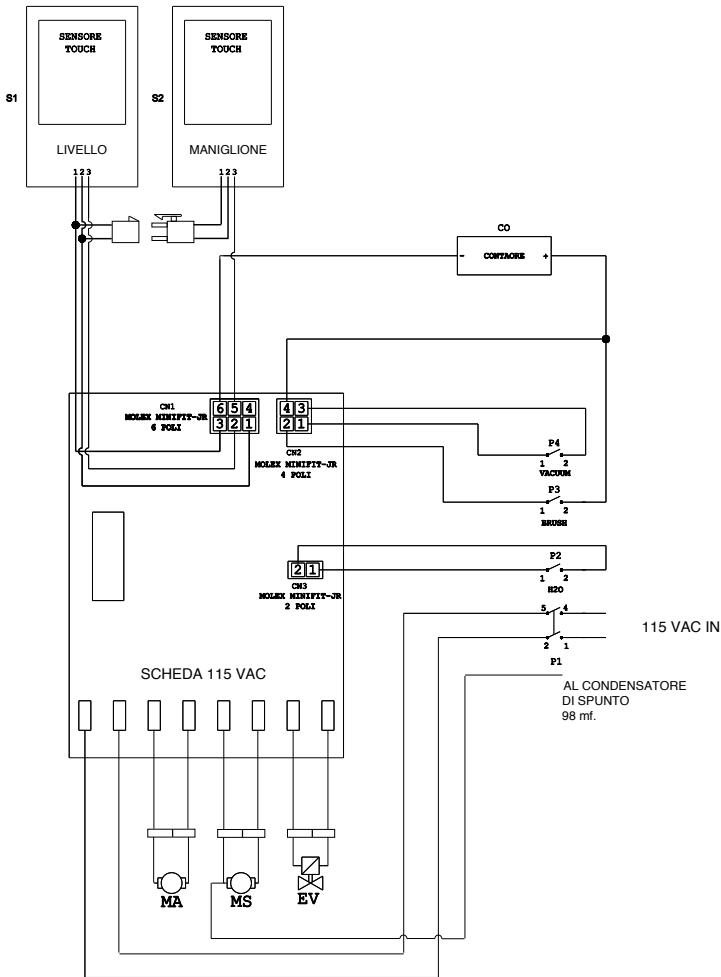

COHour counter
 CN 1 Sensor board connector
 CN 2 switch board connector
 CN 3EV switch board connector
 MA..... Vacuum motor
 MS Brush motor
 EV Solenoid

P1 Switch
 P2 EV Switch
 P3 Brush switch
 P4 Vacuum switch
 S1 Recovery level touch sensor
 S2 Handle touch sensor

FR 30 - FR 45 TOUCH 230 VAC

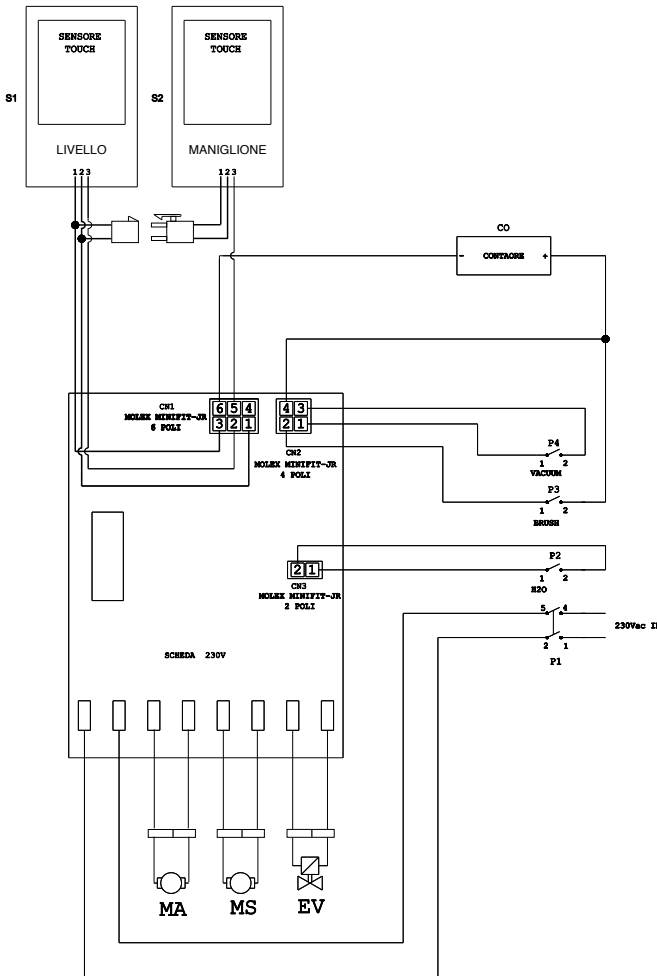

CO Hour counter
CN 1 Sensor board connector
CN 2 switch board connector
CN 3 EV switch board connector
MA Vacuum motor
MS Brush motor
EV Solenoid

P1 Switch
P2 EV Switch
P3 Brush switch
P4 Vacuum switch
S1 Recovery level touch sensor
S2 Handle touch sensor

ghibli & wirbel

Professional Cleaning Machines Since 1968

DEALER

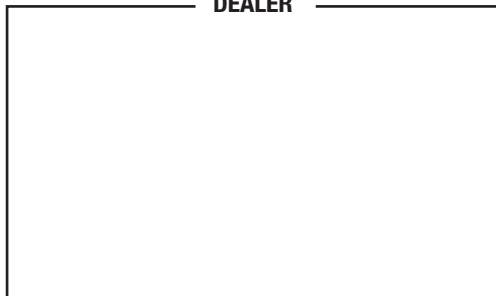

Cod. 49.0219.00 - 2[^] ed. - 10/2018

Ghibli & Wirbel S.p.A.

Via Circonvallazione, 5 - 27020 Dorno PV - Italia
P. +39 0382 848811 - F. +39 0382 84668 - M. info@ghibliwirbel.com

www.ghibliwirbel.com

100% MADE IN ITALY

A COMPANY GROUP OF RIELLO INDUSTRIES

